

# Development of Divertor Tungsten Coatings for the JET ITER-like Wall

G. F. Matthews<sup>a</sup>, P.Coad<sup>a</sup>, H.Greuner<sup>b</sup>, M.Hill<sup>a</sup>, T.Hirai<sup>c</sup>, J.Likonen<sup>g</sup>, H.Maier<sup>b</sup>, M.Mayer<sup>b</sup>,  
R.Neu<sup>b</sup>, V.Philipps<sup>c</sup>, R.Pitts<sup>k</sup>, V.Riccardo<sup>a</sup>, and the ITER-like Wall Team<sup>a-j</sup>

<sup>a</sup>Euratom/UKAEA Fusion Association, Culham Science Centre, Abingdon, UK

<sup>b</sup>Max-Planck-Institut für Plasmaphysik, EURATOM Association, 85748 Garching, Germany

<sup>c</sup>Forschungszentrum Jülich, Euratom Association, Jülich, Germany

<sup>d</sup>EFDA-Close Support Unit, Culham Science Centre, Abingdon, UK

<sup>e</sup>Alfvén Laboratory, Royal Inst. Technology (KTH), Assoc. EURATOM-VR, Stockholm, Sweden

<sup>f</sup>Association Euratom-CEA, Cadarache, DSM/DRFC, Saint Paul Les Durance, France

<sup>g</sup>Association Euratom-TEKES, VTT, Finland

<sup>h</sup>Association Euratom-ENEA, Frascati, Italy

<sup>i</sup>Nat. Inst. for Laser, Plasma and Radiation Physics, Assoc. Euratom-MEdC, Bucharest, Romania

<sup>j</sup>Association Euratom/SCK-CEN, Boeretang 200, 2400 Mol, Belgium

<sup>k</sup>EPFL SP CRPP Bâtiment PPB, Station 13 CH-1015 Lausanne, Switzerland

## Abstract

The main objectives of the JET ITER-like Wall Project are to provide a beryllium main wall and tungsten divertor with at least a 4 year lifetime to allow full evaluation of the materials and related plasma scenarios for ITER. Tungsten coatings will be used over most of the divertor area and this paper describes the latest developments in the coating technology and

an analysis of the implications for the coating lifetime and machine operation. Both steady state and transient heat loads are assessed.

PACS: 52.40.Hf, 52.55.Fa, 82.15.Ef

JNM Keywords: Tungsten, Coatings, Plasma-materials interaction

PSI-18 Keywords: Tungsten, Coating, Divertor

Corresponding author Dr. Guy Matthews

Corresponding author address: EURATOM/UKAEA Fusion Assoc., Culham Science Centre, Abingdon, Oxon, OX14 3DB, UK

Corresponding author email: [guy.matthews@jet.uk](mailto:guy.matthews@jet.uk)

Presenting author: Dr. Valeria Riccardo

Presenting author e-mail: [valeria.riccardo@jet.uk](mailto:valeria.riccardo@jet.uk)

## **1. Introduction**

In October 2004 a workshop was held to discuss the options for an implementing an ITER-like Wall in JET. The outcome of this meeting was a proposal to implement an all tungsten divertor and beryllium main wall which was approved in April 2005 [1] as the main element in a larger package of JET upgrades (EP2) [2]. This choice is now convergent with the current material choice for the DT phase of ITER. It was not feasible to re-engineer the whole of the JET divertor for solid tungsten or a different type of CFC and so a programme of R&D was launched to test 14 different types of W-coatings on JET relevant 2D CFC [3]. To manage the risk that thick coatings were not technologically feasible, R&D was also launched into the design of a bulk W tile to be positioned at the outer strike point [4,5].

## **1.1 Selection of W-coatings for JET**

In March 2006 the outcome of the 9months programme of W-coating R&D was reviewed. The reference divertor configuration which was then selected is shown in Fig. 1. Due the limited availability of 2D CFC material, time for production and testing in the GLADIS ion beam facility [3], relatively small samples were used (~8cm×8cm). Tests were also carried out with ELM-like loads in the JUDITH1 e-beam facility [6]. The results showed that 200µm VPS coating with W/Re interlayer produced by Plansee performed at least as well as the thin PVD coatings (5&10µm) under steady heat loads. In response to ELM-like loads however, the VPS coating performed better, possibly due to the fact that the heat pulse did not penetrate to the interface between the CFC and the coating on the short timescale of the pulse. Also it is obvious that a thicker coating will give better margin on the normal erosion lifetime. However, it was also recognised at this time that there were risks in scaling VPS technology to realistic tiles and in mass production. For this reason a bulk W tile (Tile 5 in Fig. 1) was included in the project.

For main chamber tiles requiring W-coating, the best performing of the thin PVD coating systems was selected. This was a 10µm W coating with Mo interlayer produced by CMSII (combined magnetron sputtering and ion implantation). This coating process has now been successfully developed to an industrial scale process [7].

## **2. Scaling of W-coating Processes to Realistic Tiles**

After the R&D phase of the ITER-like Wall project was completed, work began on scaling up the VPS W-coating process for industrial production of divertor tiles. Coating 2D CFC material with tungsten is intrinsically challenging not only because of the anisotropic thermal expansion mismatch [3] but also because of the variable micro-structure of the CFC surface.

Many details can have an effect on performance including the exact properties of the base material, the machining process used to cut the surface, the angle at which the fibres meet the surface and the preparation of the surface. The quality of VPS coatings is also affected by numerous parameters from the angle of the plasma torch to the cooling rate between passes over the surface. This makes a complex multi-variable problem and for this reason it was decided to produce sample tiles for testing in GLADIS whose material, machining, geometry, size, surface preparation and coating processes were very close or identical to those of the production tiles. The design selected for the test tiles was closely based on Tile 7 (T7-like), Fig. 1, which was felt to be the most challenging.

Due to early problems experienced in trying to scale the VPS coatings to realistic size tiles, testing of a 14 $\mu$ m PVD W/Re multi-layer, Fig. 2, similar to the base layer of the VPS coating was also started to provide a fallback option. This multilayer structure improves the ductility at the interface with the CFC and provides a diffusion barrier to restrict the formation of brittle tungsten carbides at high temperatures to the first tungsten layer [8].

All the divertor tiles (1-8) apart from Tile 0 (Fig. 1) have fibre planes normal to the surface. Although 5 $\mu$ m PVD W-coatings were successfully tested on parallel fibre tiles during the R&D phase, thick VPS coatings were not evaluated. More recent work to fill this gap has shown that due to low thermal expansion of parallel fibre CFC in both surface dimensions, a satisfactory VPS coating cannot be achieved even before heat flux testing. The 14 $\mu$ m PVD W/Re multi-layer however, performed well in GLADIS tests of realistic tiles whose geometric features were representative of Tile 0. No defects were observed after thermal cycling of this tile type at a level appropriate for its peripheral location in JET (4MW/m<sup>2</sup>, 0.5s, 100cycles).

## 2.1 200 $\mu\text{m}$ VPS W-coating tests

The T7-like tiles are half the length of a real tile 7 (15cm long by 17cm tall) but otherwise geometrically similar including details such as a 1mm edge radius which was shown to be necessary by the earlier R&D for VPS coatings. Seven of these tiles were coated using the standard W/Re multi-layer PVD base layer with a VPS layer on top but only two were of acceptable quality for testing in GLADIS.

The first VPS tile tested showed hot spot early in the test and melting after exposure to 43 pulses at 16.5MW/m<sup>2</sup> of duration 0.5s ( $T_{\text{max}} = 1200^{\circ}\text{C}$ ). The second tile achieved 100 cycles without failure for a heat flux of 10.5MW/m<sup>2</sup> of duration 1s ( $T_{\text{max}} = 1050^{\circ}\text{C}$ ).

Examination of the sectioned tiles after testing, Fig. 3, revealed that, in contrast to the small R&D samples, the VPS coating had a layered structure (corresponding to each pass of the plasma torch used to deposit the layer). The greater time for cooling between passes and halo of poorly adhered material at the edges of the torch footprint are likely causes of these sub-layers. Analysis of the melted coating showed that delamination within the VPS coating was responsible. This mode of failure appeared identical to that observed in ELM-like transient heat load tests on similar coatings in the JUDITH1 e-beam high heat flux facility (0.33GWm<sup>-2</sup>, 1ms, 500pulses). The failures tend to occur at central ridge (radius 50mm) because this is where there is a component of the compressive stress normal to the surface.

## 2.2 14 $\mu\text{m}$ W/Re multi-layer tests

Similar GLADIS and JUDITH1 tests were carried out on the thin PVD coatings as on the thick VPS coatings. The slow thermal cycling in GLADIS produced no significant coating defects. However, a few very small hot spots (<10) appeared in the first few cycles of the ion beam but these did not increase in number when as a total of 200 pulses was applied.

Subsequent SEM analysis showed that these were caused by small buckling defects [3] which were <0.5mm across and located on top of the fibres which run along the tile surface. The small non-growing number of these defects indicates a highly localised adhesion problem at the interface between the W-coating and the carbon fibres running along the CFC surface. The total area of carbon exposed by such defects is miniscule and not a threat to the objectives of the project. Previous GLADIS tests on a full size Tile 5 showed no defects at all. During production a significant fraction of the actual divertor tiles will be heat flux tested in the JUDITH2 facility [9] under conditions similar to those of the GLADIS tests but for fewer cycles to ensure uniformity of the production coating quality.

The JUDITH1 ELM-like loading tests were also very successful with no damage observable after 1000 cycles at  $0.33\text{GWm}^{-2}$  of duration 1ms. The surface temperature rise during this fast pulse is not directly measured but comparisons with finite element calculations show that it can be reasonably approximated for the JET material by the analytical semi-infinite solid formula  $\Delta T[^\circ\text{C}] \sim 56P[\text{MWm}^{-2}]t[\text{s}]^{0.5}$ . This predicts a temperature rise of  $560^\circ\text{C}$  for the  $0.33\text{GWm}^{-2}$  1ms pulses ( $0.33\text{MJm}^{-2}$ ). When the power density was increased to  $0.4\text{GWm}^{-2}$  ( $0.4\text{MJm}^{-2}$ ) for a further 100pulses, slight cracking and melting was observed along the in-plane fibres. The coating on top of the fibres which run into the surface showed no damage.

### **3. Experimental Programme Requirements / Constraints**

#### **3.1 W-Coating Lifetime due to physical sputtering**

The erosion of tungsten marker tiles exposed in JET provide us with the most reliable way of estimating the erosion rate of a fully coated divertor. Two experiments have been carried out:

- i. A  $3\mu\text{m}$  thick PVD W-stripe 2cm wide was exposed to 42,000s of plasma operation (campaigns C5-14). The highest erosion was observed on Tile 7 [10] and at the most

common strike point position, the peak mean erosion determined from ion beam analysis is 0.06nm/s. No erosion of the W-stripes was observed at the inner divertor due to the fact that it is a deposition zone.

- ii. A single Tile 5 was coated with two W-stripes 8cm wide toroidally, one was 1.8 $\mu$ m thick and the other 0.8 $\mu$ m thick [11]. In this case, 38,000s of plasma (campaigns C15-C18) was run on the tile. The peak mean erosion rate from ion beam analysis is 0.01nm/s.

These erosion rates are very similar to those seen in ASDEX-Upgrade (<0.06nm/s) [10].

The lower erosion rate seen on Tile 5 compared to Tile 7 is not fully understood.

However, the tungsten re-deposition fraction is expected to be higher for the wider stripe but the calculations are complicated by the fact that it is very density sensitive [12] and that the erosion is totally dominated by impurity sputtering and not by deuterium ions.

### **3.2 The effect of surface roughness**

The simple picture of uniform erosion of the coating does not hold at the microscopic level. SEM analysis shows that JET coatings can be eroded up to 4 times quicker on a length scale linked to the surface roughness [10]. Figure 4 shows that in both ASDEX and JET there is similar offset linear behaviour. Although the fine grain graphite used in ASDEX is much smoother, the W-coating was 0.56 $\mu$ m compared with 3 $\mu$ m in JET. A conservative view is that the peak local erosion in JET is four times the mean value determined by ion beam analysis i.e. 0.24nm/s for the tile 7 data and 0.04nm/s for Tile 5. However, one might expect a lower rate once the coating is thicker than the surface roughness.

### **3.3 Risk of coating damage due to giant ELMs**

The largest ELMs seen in JET which are well documented are 0.7MJ [13] with a rise time of 200 $\mu$ s but with the heating upgrade which is being carried out in parallel with the wall [2], ELMs up to 1.6MJ might be possible. In a deliberately low flux expansion configuration (~4), the temperature rise at the outer strike point for the 0.7MJ ELM was  $\Delta T=780^{\circ}\text{C}$ . The JUDITH1 results suggests that ELMs with an energy over 0.5MJ run in low flux expansion configurations have the potential to damage the 14 $\mu$ m multi-layer coatings at the outer strike point.

### **3.4 Impact of coating failures**

Experience in ASDEX-Upgrade has shown that local coating failures usually do not jeopardise the scientific goals or operation of the machine. Most of the main chamber in ASDEX is coated with 1.5-4 $\mu$ m PVD W. The W-coating has been eroded from tile edges in the upper divertor but there is no evidence that the tungsten or carbon released have affected the programme. VPS coatings between 200 and 500 $\mu$ m thick on fine grain graphite (a good expansion match to W) have been used in the ASDEX divertor for some time. Occasional failures of VPS coatings have occurred due to delamination at interface with the graphite and more recently sub-layer delaminations, as seen in the JET R&D. The results cannot be discussed in detail here but the general conclusion is that failures of thick VPS coatings have the potential to affect machine operation through elevated tungsten levels, although this is not always the case. There is also more potential for progressive damage to occur with thicker layers due to peeling and formation of droplets which do not wet a carbon surface.



## 4. Conclusions

The decision to stop further development of VPS W-coatings for the JET divertor tiles resulted from problems encountered in scaling the process to full sized tiles. Recent experience in ASDEX-Upgrade has shown that even with a well matched substrate VPS W-coating failures can occur which affect subsequent machine operation. In the case of JET, this would represent an unacceptable risk due to the length of time required for repairs.

From extrapolations of existing *in-situ* tungsten marker analysis and allowing for the effect of surface roughness, the lower limit for the lifetime of a 14 $\mu$ m W/Re multi-layer coating is about 60,000s. To provide more margin, tests are underway at the time of writing, on PVD coatings up to 30 $\mu$ m thick (14 $\mu$ m W/Re + 16 $\mu$ m W). The lifetime of the coating could also be greatly extended by limiting the number of pulses whose outer strike point is run off the bulk tungsten Tile 5. Giant ELMs have the potential to damage the W-coating in the JET divertor but a relatively modest restriction on maximum ELM size and minimum flux expansion is required to avoid this for plasma configurations which are not run on the bulk W tile. We therefore expect that the lifetime of the W-coated areas of the JET divertor will be sufficient for at least 4 years of exploitation of the ITER-like Wall and will impose only very modest constraints on the planning of the EP2 programme.

## Acknowledgement

This work was conducted under EFDA and partly funded by Euratom

## References

[1] G.F.Matthews, P.Edwards, T.Hirai et al., Phys. Scr. T128 (2007) 137

[2] J.Pamela, G.F.Matthews, C. Philipps, R.Kamendje et al. J. Nucl. Mater. 363-365 (2007)

137

[3] H.Maier, R.Neu, H.Greuner et al., J. Nucl. Mater. 363-365 (2007) 1246-1250

[4] P.Mertens et al., this proceedings.

[5] T.Hirai et al., Phys. Scr. T128 (2007) 144

[6] T. Hirai et al., Fusion Eng Des 82 (2007) 1839–1845

[7] C.Ruset et al., "Industrial scale 10 microns W coating of CFC tiles for the ITER-like Wall project", paper accepted for presentation at SOFT 2008.

[8] K.Tokunaga, T.Matsubara, Y.Miyamoto et al., Journal of Nuclear Materials 283-287 (2000) 1121-1127

[9] P. Majerus et al., Fusion Eng Des 82 75–79 (2005) 365–369.

[11] P.Coad et al., this proceedings.

[10] M. Mayer, Phys. Scr. T128 (2007) 106

[12] A.Thoma et al., Plasma Phys. Control. Fusion **39** (1997) 1487–1499

[13] R.Pitts et al., this proceedings.

## Figures

*Fig. 1 Cross section of the JET divertor showing the numbering system for the JET tiles. In 2006 200 $\mu$ m VPS was selected as the preferred W-coating option for tiles 0, 1, 3, 4, 6, 7 and 8. A 10 $\mu$ m CMSII coating process was chosen for tiles 5a, B and C whilst solid tungsten was selected for tile 5 which is used in plasma configurations with ITER relevant triangularity.*

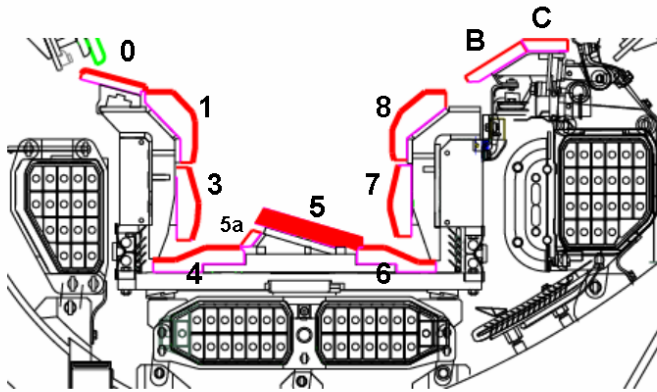

*Fig. 2 Cross section of the 14 $\mu$ m PVD W/Re multi-layer back-up coating taken with an optical microscope. The layer thickness starting from the CFC are: 6 $\mu$ m Re, 2 $\mu$ m W, 2 $\mu$ m Re and a top layer of 4 $\mu$ m W.*

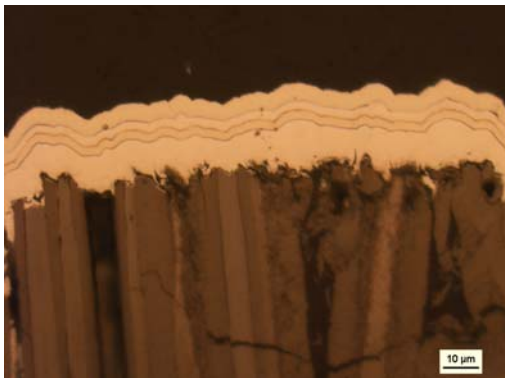

*Fig. 3 Stratified structure of the 200 $\mu\text{m}$  coating as viewed with an optical microscope after exposure in GLADIS. The coating is actually almost twice as thick as the nominal value. A section through a normal thermal expansion crack can be seen.*

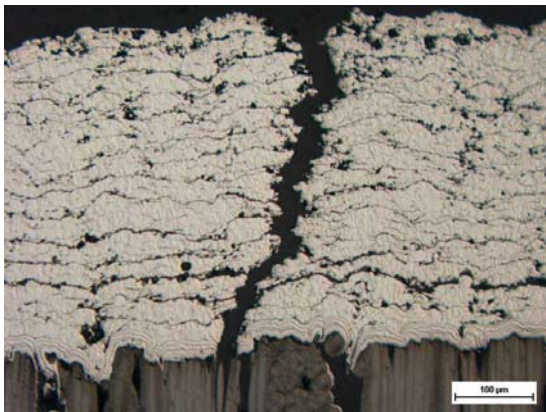



Fig. 4 Exposed area of carbon vs. mean erosion for 0.56 $\mu\text{m}$  thick W-coatings on fine grained graphite in ASDEX-Upgrade compared with 3 $\mu\text{m}$  on 2D CFC in JET. The SEM images, which are 250 $\mu\text{m}$  wide, show the progressive exposure of carbon in JET.

Note that if too long the SEM images will be omitted or combined with the graph.

