

TRANSITION FROM CONSTRUCTION TO OPERATION PHASE OF THE WENDELSTEIN 7-X STELLARATOR

H.-S. Bosch, R. Brakel, M. Gasparotto, H. Grote, D. A. Hartmann, R. Herrmann, M. Nagel, D. Naujoks, M. Otte, K. Risse, T. Rummel, A. Werner
Max-Planck-Institute for Plasma Physics, EURATOM Association, Wendelsteinstr. 1, 17491 Greifswald, Germany

Corresponding author e-mail: Bosch@ipp.mpg.de

Abstract—Assembly of the superconducting stellarator Wendelstein 7-X is well advanced, and commissioning of the device is being prepared. A first draft of the commissioning tasks has been developed and will be discussed in this paper.

Keywords—Wendelstein 7-X; Commissioning; Operation

I. INTRODUCTION

The “fully-optimized” stellarator Wendelstein 7-X is presently under construction at the Max-Planck-Institute for Plasma Physics (IPP), Greifswald, Germany [1]. Assembly of the device, the periphery systems and the diagnostic and heating systems is well advanced and is scheduled to be completed in fall 2014 [2]. After the commissioning phases that will end with the preparation for first plasma and in particular with the measurement of the magnetic flux surfaces in the limiter configuration, the first stage of plasma operation (OP1.1) is planned to start in 2015. In this phase, plasmas with a duration up to 1 sec and ECR heating up to 3 MW are planned with the main objective to test all the systems together including some basic diagnostics. Following this 3 month experimental phase, in a further assembly phase the inertially cooled temporary divertor units (TDU) will be installed. In the following, second stage of the first operation phase (OP 1.2) plasmas with up to 10 s at a heating power of 8 MW will be investigated to confirm the stellarator optimization and to develop integrated high-density scenarios. After completion of the systems (upgrade of heating and diagnostics and installation of the High Heat Flux divertor) the second operation phase (OP 2) will start. The physics and technological issues of steady-state fusion device operation will be addressed in OP 2[3].

Recently, a task force has started to detail the first commissioning phase, which will commence towards the end of assembly phase.

The commissioning of Wendelstein 7-X consists of two steps with increasing levels of system integration.

I. Local commissioning (LC) of technical components: There the component is run by the local control system. Instrumentation and all other peripheral components are included as required. In

general, local commissioning will be done before the end of Wendelstein 7-X assembly.

II. The integrated commissioning (IC): This is the step-wise integration of all separate components into the overall system, the central device control and the central data acquisition system.

This paper will discuss the CoDaC (Control, Data acquisition and Communication) system involved in all phases of commissioning, the different phases of the Integrated Commissioning, and present a first draft of the commissioning schedule.

II. CONTROL AND DATA ACQUISITION OF W7-X

CoDaC plays a crucial role for both commissioning steps [4], since its architecture is based on a distributed control and data acquisition system [5], in which each component, like diagnostics, heating devices and auxiliary systems, is equipped with a local control system: Firstly, local control and data acquisition is already required for LC of any component. Secondly, full documentation of engineering data and the device control is required from the start, i.e. from the beginning of the IC. In fact, Central Device Control consists of the Central Safety System (fulfilling all requirements for the personnel safety as primary requirement and also hardware protection controlled by the Central Interlock System) and the Central Control System which is responsible for operational management and sequence control (plasma operation, glow discharge, baking, idle state, ...) for different operational phases of the device. The main function of the Central Device Control is to guide and control the global behavior of the W7-X machine. This central system will be tested during the IC phases.

The CoDaC systems will be put into operation synchronized to the commissioning plan. Since each component is equipped with a local safety and control system, the LC is used for the respective tests. Already in this phase, the data acquisition system is being used to archive all the engineering data produced by that component. The local PLCs (programmable logic controller) send data blocks to dedicated data acquisition station 24

hours each day. All the data will be archived with central Experiment Data Archive. Collecting data, in particular for the machine instrumentation in the early phases, will facilitate error analysis and document the mechanical and thermal behavior of the complex device for comparison with later operation phases.

The commissioning of the Central Control System and the Central Safety System is required before the first phases of IC. Correlated actions of different components will be introduced step by step into the control system in order to support the IC and to keep the tests of central systems at low complexity. In a later stage of the IC, the fast control system based on segment control with a real time system [6] will support fast correlated actions, e.g. where fast camera data acquisition has to be synchronized with mechanical actuators. This phase also prepares the first plasma operation.

III. COMMISSIONING PHASES

The following sequence of phases has been defined for the integrated commissioning:

1. Vacuum tests of the cryostat
2. Cryogenic tests of the cryostat
3. Normal conducting coil systems tests
4. Vacuum tests of the plasma vessel
5. Superconducting magnet coil systems tests
6. Preparation for the first plasma

1. *Vacuum tests of the cryostat*

While all electrical connections inside the cryostat, especially the superconducting joints [7] between the bus bars [8], have been tested after each assembly step, a global electrical test of these connections has to be performed before the cryostat is closed. Also, in this phase, the vacuum system for the interspaces of the multilayer port bellows [9] has to be commissioned and the leak tightness of these bellow interspaces has to be confirmed.

After the completion of the current leads assembly into the cryostat, this vessel can be closed and pumped down. Although practically all welds on the cryostat, its domes, the ports and flanges have been checked for leak tightness after each weld, a global leak test has to be performed. Also, the extensive pipe work for water cooling of the plasma vessel and ports, and the complex helium pipe work for the cryogenics, i.e. for cooling the superconducting coils, the bus-bars, the current leads, central support structure, and the thermal shields [10] have to be leak checked and tightness has to be confirmed. This latter part of the leak tests has already a time overlap with the first cryogenic tests, since a variation of the helium pressure in the lines is desired. The planned duration for this phase is estimated to be 19 weeks.

2. *Cryogenic tests of the cryostat*

As first step in this phase, pressure tests and final leak tests on the helium pipe work outside the cryostat (between cryostat and the last valve of the cryo plant) have to be made. These tests contain the last welding seams at the process pipes connecting the transfer line from the valve box to the

ring manifolds in the W7-X cryostat, the connection to the quench gas exhaust system with safety valves and rupture discs and the connection to the 14 helium return pipes at the warm side of the current leads.

Then all helium pipes have to be cleaned. This is done by repeatedly pumping and purging all individual circuits with helium gas. Then warm helium gas is circulated through all circuits using the internal cold adsorbers of the refrigerator to purify simultaneously the circulated helium gas. The progress of cleaning is checked with the gas analyzer unit. The maximum allowed impurity in the helium flow is 10 vpm. During that process a hydraulic check of the different circuits is done. 90 manual valves dedicated to the housing cooling of the 70 coils, to the 10 circuits of the supports structure cooling and thermal shield cooling are adjusted to balance the helium flow in parallel circuits.

Then the cool down of the cryostat can be started. The cool down rate should not exceed 2 K/h and the maximum temperature difference between helium inlet temperature and the coil temperatures must not exceed 50 K. The cryo plant, the thermal shield, the 14 current leads and the cold mass of W7-X will be cooled down simultaneously. The cryo shield is only cooled down to 80 K. A duration of four weeks is expected for the first cool down.

After reaching this important milestone, different operation modes have to be tested. The temperature distribution on the cold components and the heat loads on the components will be checked to make sure that no unacceptable thermal gradients occur and the heat loads are within the design values. The overall mass flow, the pressure drop and the flow distribution are checked and adjusted if required. The three most important operation modes of the cryo plant are [11]:

a) Long stand-by mode: In this mode the cold components are held at a temperature of about 100 K during longer breaks within experimental campaigns. Only the high pressure stage compressor is working when no liquid helium is produced.

b) Short stand-by mode: For shorter interruptions of experimental campaigns, e.g. during nights or over weekends, the cold components are kept at a temperature of about 10 K. Helium gas is flowing through all cold components. No cold machines like circulators or compressors are in operation. Liquid helium is generated to boost the cooling power during standard mode.

c) Standard mode: for operation of Wendelstein 7-X with magnetic fields up to 2.5T. In this mode, the helium inlet temperature into all cold components will be 3.9K. This requires the operation of the cold machines like one cold circulator and a cold compressor. The cold circulator pumps supercritical helium through the coil housings. The cold compressor generates a sub atmospheric pressure that is required to produce helium below the normal boiling temperature in the subcooler. The refrigerator control reacts very sensitive to loads on the cryo plant. The control parameters need to be adapted to the actual heat loads, the pressure drop and the inertia of the system.

3. Normal conducting coil system tests

For the modification of the plasma edge, especially of the magnetic islands which determine the power loading of the divertor plates, two flexible saddle coils systems have been implemented:

Ten so-called control coils are installed behind each of the 10 divertor target plates. They will be used to adjust the plasma strike point and equalize the power load onto the 10 divertor targets [12]. To this purpose each coil is operated by a separate power supply.

In addition, five so-called trim coils are mounted on the outside of the cryostat (symmetrically to the midplane) [13]. These, again independently supplied, coils can correct for asymmetries in the stellarator magnetic field, as it could result from an out-of-tolerance assembly of the 70 modular field coils, and can be used for physics studies on the plasma edge. For this, each of the power supplies can provide the maximal coil current with a sweep frequency of up to 10 Hz.

The coils and the power supplies are part of a collaboration program between the Princeton Plasma Physics Laboratory, Oak Ridge National Laboratory and the Wendelstein 7-X project, that is funded by the U.S. Department of Energy. IPP is responsible for the auxiliary systems like cooling circuits grid transformer or control systems.

During this part of the IC, each of the 15 coils will be charged separately up to their nominal current first, before all the coils are charged up to the full current field simultaneously. The controllers of the power supplies of the control coil and trim coils that at the company have been tested only in short circuit or with a resistive dummy load have to be adjusted w.r.t. accuracy, long term stability, temperature drift. Not only the capability of carrying the full power will be tested, but also the function of the safety systems, the interfaces to the Central Device Control and the cooling circuit capacity. This phase is expected to take 7 weeks.

4. Vacuum tests of the plasma vessel

While the phases 1. – 3. can be performed when there is still assembly work in the plasma vessel going on, for (almost) all following phases the plasma vessel has to be closed. After evacuating the plasma vessel [8], a global leak test of all welds performed on-site on the vessel and the ports will be performed. Next, all the water pipe-work (for cooling in-vessel components and diagnostics) and the helium pipe-work (for cooling the cryo-pump to be installed later) inside the plasma vessel will be leak-checked. Also the plasma gas fuelling system will be taken into operation in this phase, this phase is expected to take 10 weeks.

5. Superconducting magnet coil system tests

In this phase the superconducting coil system of Wendelstein 7-X, consisting of 50 non-planar coils (NPC) of five types [14] and 20 planar coils (PC) of two types [15], which has been cooled down in phase 3, will be operated with current for the first time in W7-X. All ten coils of the

same type are connected in series by superconducting bus bar sections and supplied via two high temperature superconductor current leads by one power supply. It has to be noted that the coils and the current leads have already been operated up to their nominal current separately during the acceptance tests after fabrication, but the bus bar sections including their joints to the coils and the current leads will be energized for the first time. Furthermore the power supplies and the magnet safety system have been operated so far by using normal conducting dummy loads. Their inductance is different from the superconducting coil circuit by a factor of 1000 and also the resistance differs by a factor of 10 from the superconducting coil circuit.

The following prerequisites or tests must be accomplished successfully before the first coil circuit can be charged:

- Proper function of helium power plant and additional water cooling circuits for the power supply cabinets.
- The liquid helium flow must be well balanced and stable in the ten superconducting coils as well as in the superconducting bus system and in the current leads.
- High voltage test against ground potential
- Test of Quench Detection system
- Test of the magnet safety system at zero current
- Communication to the control systems.

Each of these seven coil circuits will be energized up separately first to a current of about 2 kA, later to full nominal current. During the first step, also the trigger levels of the quench detection units will be adjusted, and the magnet safety system will be tested with a fast discharge. During the loading of the coils with current, the mechanical behavior of the coils will be monitored with strain gauges and contact sensors to detect unexpected movements and deformations. This mechanical behavior has been calculated with FEM modeling, also giving the limits for these movements. The experimental measurements in this commissioning phase will be used to validate the FEM-calculations [18]. In the second step the coil circuits will be charged separately up to their full current. Also during this phase a fast discharge will be initiated followed by a further full current operation to check the proper behavior of the coils regarding mechanical deformation, movement, helium temperature and pressure evaluation.

Regular high voltage tests will be carried out (also during current operation) to check the integrity of the electrical insulation.

At the end of this phase, the interaction of the seven, inductively coupled, coil circuits has to be evaluated and the controllers of the power supplies have to be adjusted. All coil circuits will be charged simultaneously up to a current of about 14 kA, which is equivalent to an induction of 2.5 T on the magnetic axis. In W7-X eight reference magnetic configurations are defined, requiring different currents in the coil groups. All eight configurations will be tested and the

electrical, hydraulic and mechanical behavior of the superconducting magnet system will be checked and compared with the expectations. This phase contains also tests of magnetic configurations changes, which requires high controller stability during the change of the electrical current in one or more coil circuits while the current in the other coil circuits has to remain constant. This phase is planned to be carried out in parallel to the phase 4 and is expected to take 10 weeks.

1.2, will be performed in this phase, e.g. baking system, glow discharge system, gas injection system, ...).

Since in a stellarator the magnetic flux surfaces in principle are created by external coils only, these so-called vacuum magnetic flux surfaces (without the influence of the plasma pressure) can be measured without plasma [19]. These measurements assess the quality of the vacuum flux surfaces, i.e. deviations of the desired magnetic field, e.g. due to coil positioning being outside the tolerances required. To that purpose an electron-beam is emitted in the evacuated

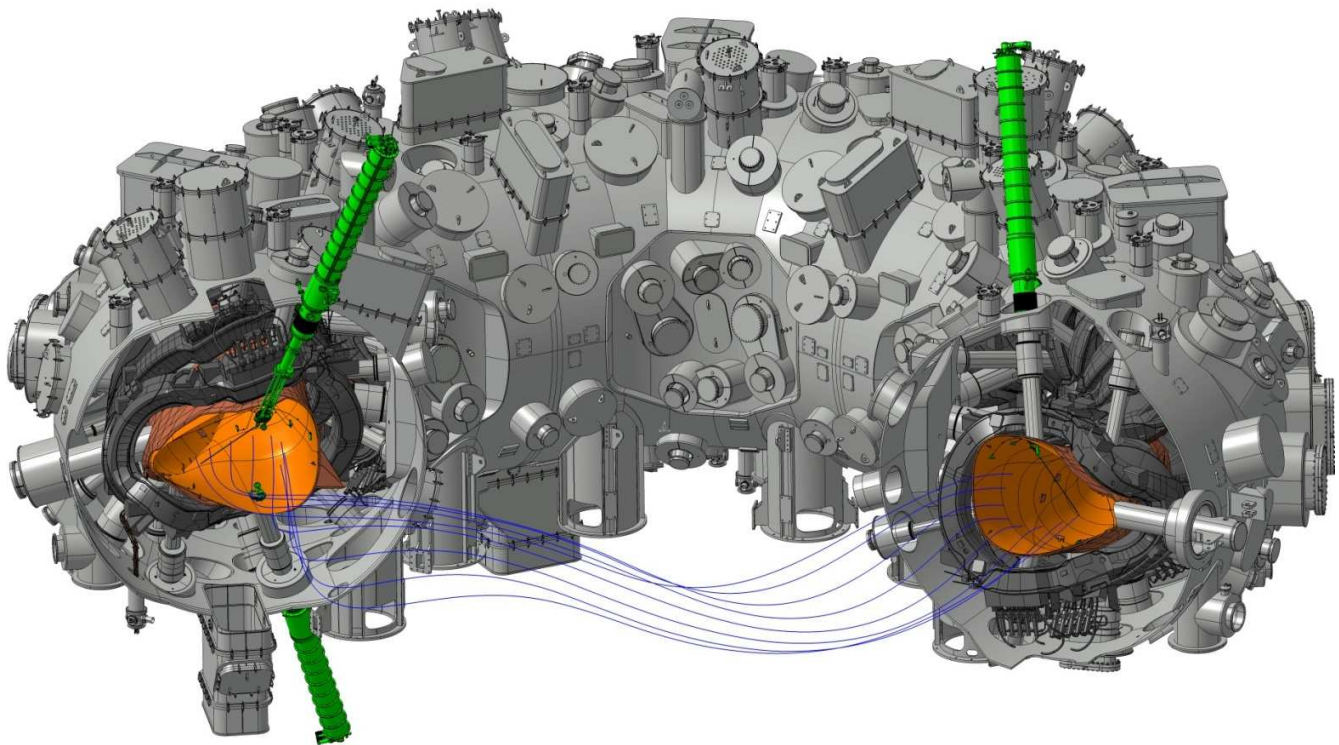

Fig. 1. Manipulators of the magnetic flux surface diagnostic (green) showing the position of the electron source at the right manipulator at a flux surface (blue) and the intersecting fluorescent detectors on the left.

6, Preparation for first plasma

While the local commissioning of the diagnostics will be performed in parallel to the previous IC phases, those diagnostics needed to guarantee safe operation (density control, impurity monitor, magnetic diagnostics...) will be tested in this phase of IC. The neutron counter system will have to be calibrated in the final assembly state of the Wendelstein 7-X device to have the complete neutron scattering environment. A neutron source will be moved along a toroidal rail along the midplane in order to mimic a toroidal line source.

The ECRH system will be installed and aligned before the closure of the plasma vessel, planned beginning of January 2015, and local commissioning will be performed during the first phases of IC.

The commissioning of all the other main components, and diagnostics, needed to operate W7-X in OP1.1 and OP

plasma vessel with energized magnetic field coils. This low-energy beam follows the magnetic field lines until intercepted by a fluorescent detector in a fixed plane, thereby creating a 2-dimensional Poincaré-plot of the magnetic flux surface. The signal generated by the fluorescent detector will be observed by a sensitive CCD camera. The diagnostic foreseen for W7-X will allow to measure the flux surfaces in the triangular plane between module 5 and 1, and between module 2 and 3, which are toroidally separated by an angle of $\varphi=144^\circ$. Next to the experimental confirmation of the existence of closed and nested flux surfaces it will thus be possible to check the stellarator symmetry by comparing the results of the measurements in the two different planes. In each of the two planes either the electron beam or the fluorescent detector is operating. Thus it is possible to measure subsequently the magnetic flux surfaces in two modules for the same magnetic configuration. For this purpose manipulators are designed carrying a fluorescent detector rod on which's top end a small electron gun will be additionally installed. The manipulator allows positioning the electron gun from anywhere between the magnetic axis and the last closed flux surface.

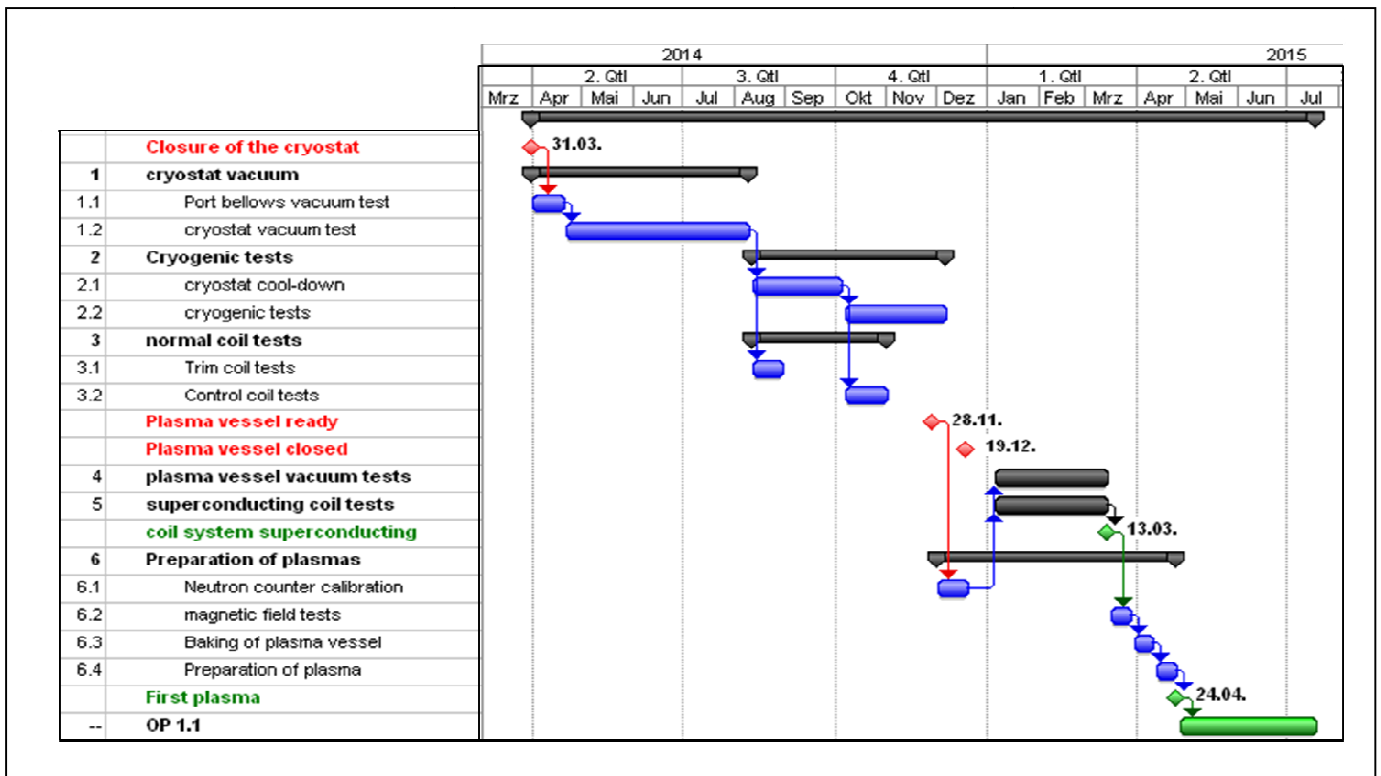

Fig. 2. Draft schedule for the Wendelstein 7-X integrated commissioning schedule (as of June 2013).

In order to reach the edge islands it is also possible to tilt the rod. The combination of an axial and a circular movement allows the fluorescent detector rod to cover nearly the whole flux surfaces including the edge magnetic islands. In total 3 manipulators installed in 2 different module planes will be available for the measurements.

The fluorescent method can be applied starting from a magnetic field of about 0.1T up to full field. By repeating the measurements for a fixed magnetic configuration at increasing field strength it is therefore possible to draw indirectly conclusions on possible settlement effects of the magnetic coil system.

While the fluorescent technique mentioned before is limited to measuring in a 2-dimensional intersecting plane only it is also possible to follow the 3-dimensional trajectory of the electron beam without using a fluorescent detector. For this purpose the beam will be emitted in a highly diluted background gas (e.g. nitrogen, argon or hydrogen) with a neutral pressure on the order of 10^{-5} - 10^{-4} mbar. Due to the inelastic collisional excitation of the neutrals and the subsequent light emission in the visual range the beam can be observed in the whole torus. However, in contrast to the fluorescent measurements the number of observable toroidal transits is strongly suppressed. It is planned to make use of this technique to visualize e.g. the magnetic axis and the O-points of magnetic islands.

After this test of the magnetic field quality, the plasma vessel has to be cleaned by baking to 150° C (hold time of 5

days) and by glow discharge cleaning. Following this cleaning, the first plasma trials can be performed, thereby concluding the integrated commissioning. About 9 weeks in total are expected for the tasks in this last phase.

IV. SCHEDULING OF THE INTEGRATED COMMISSIONING

With the definition of the tasks to be performed in the different phases (see chapter III), a draft schedule for integrated commissioning can be set up, considering the following boundary conditions:

- Some of the IC phases can be performed in parallel to assembly in the Plasma Vessel and in the Torus Hall. However, two important assembly milestones directly impact the schedule of the IC, in the sense that they trigger new phases: Closure of the cryostat (March 2014) is a pre-condition for phase 1 (Vacuum tests of the cryostat), while phase 4 (Vacuum tests of the plasma vessel) can start only after closure of the plasma vessel (December 2014).
- Also some of the IC-phases could overlap, i.e. in parallel to the cool-down of the cryostat and the cryogenic tests, also the normal conducting coils are commissioned, as these tasks are independent. However, with regards to safety issues, this parallelization requires enhanced efforts in treating the inter-dependencies of the different tasks.
- Local commissioning of auxiliary systems required for any of the main systems mentioned above, has to be completed in time. Compatibility of the schedules

of all the required systems is being verified at this moment.

The schedule for integral commissioning will be success-oriented: No major problems will be considered in the schedule on the basis of accurate Quality Control QC, systematically applied during the assembly with specific tests carried out both on all welds and vacuum seals and on all the electrical insulation. Nevertheless one can expect a number of problems arising from leaks, cold leaks, insulation problems, and so on, but it is difficult to quantify this beforehand, and to include such events in the schedule. On the other hand, such a success-oriented schedule also predicts the earliest start of each phase which allows for a reliable planning of all tasks that are required to be ready for this phase.

Following these boundary conditions, the schedule for the integrated commission for OP 1.1 has been derived as shown in Fig. 2. There is a clear distinction between phases 1.-3., which require a closure of the cryostat, but still allow for further work in the plasma vessel, and the remaining phases 4.-6. That have to be carried out with the plasma vessel closed. It should be noted that phase 6 "Preparation for first plasma" also includes a task, which has to be performed before closing the plasma vessel, namely the neutron counter calibration, and is therefore split in two parts. The task "magnetic field test", will overlap with the superconducting coil tests (as soon as the plasma vessel vacuum is sufficiently low), as this is an important means to test the tolerances of the coils and to confirm the proper working of the coil system.

When assembly, installation or maintenance work as well as functional tests of components are performed in parallel to the partial operation of the W7-X device during the phases 1-3, the associated safety risks must be minimized by additional safety measures.

In particular, the access control, the safety training and work organization are of vital importance. Any type of work and stay in the Torus Hall should be announced and approved by documented Permits. Special access restrictions are to be applied during transient operation processes such as vacuum generation and cool-down.

V. SUMMARY

In the fall of 2012, a task force has been established to plan in detail the commissioning of Wendelstein 7-X. The main phases of integrated commissioning have been defined and discussed in an international workshop in January 2013. Now these phases are being worked out in further detail and the interfaces to the auxiliaries are considered. In parallel, also the procedures and forms for the integrated commissioning are being developed [18].

REFERENCES

[1] H.-S. Bosch, V. Erckmann, R. W. T. König, F. Schauer, R. J. Stadler, A. Werner, "Construction of Wendelstein 7-X – Engineering a Steady-

State Stellarator", IEEE Transactions on Plasma Science, vol. 38, pp. 265-273, 2010.

- [2] T. Klinger et al., "Wendelstein 7-X Construction and Future Research Directions", proceedings of the 25th Symposium on Fusion Engineering (SOFE), San Francisco, June 2013.
- [3] H.-S. Bosch, A. Dinklage, T. Klinger, R. Wolf and Wendelstein 7-X Team, "Physics Programme for Initial Operation of Wendelstein 7-X", Contributions to Plasma Physics, vol. 8, pp. 687-694, 2010.
- [4] A. Werner et al., "Cutting Edge Concepts for Control and Data Acquisition for Wendelstein 7-X", proceedings of the 25th Symposium on Fusion Engineering (SOFE), San Francisco, June 2013.
- [5] J. Schacht, D. Aßmus, T. Bluhm, A. Dinklage, S. Heinrich et al., "Stellarator WEGA as a test-bed for the WENDELSTEIN 7-X control system concepts", Fusion Engineering and Design, vol. 83, pp. 228–235, 2008.
- [6] H. Laqua, H. Niedermeyer and J. Schacht, "Control system of Wendelstein 7-X experiment", Fusion Engineering and Design 66-68 (2003) 669-673.
- [7] K. Rummel, A. John, L. Hajduk, "Experience from the installation of the superconducting bus-bar system of Wendelstein 7-X", proceedings of the 25th Symposium on Fusion Engineering (SOFE), San Francisco, June 2013.
- [8] O. A. Neubauer, A. Charl, G. Czymek, B. Giesen, M. Sauer, L. Scheibl, J. Schruoff, R. Schick, A. Panin, A. John, S. Jung, K. Rummel and L. Wegener, "The busbar system for Wendelstein 7-X prepared for assembly and operational loads", Fusion Engineering and Design, vol. 84, pp. 1416-1419, 2008.
- [9] J. Reich, W. Gardebrecht, B. Hein, B. Missal, J. Tretter, M. Wanner, F. Leher and S. Langone, "Manufacture of the plasma vessel and the ports for Wendelstein 7-X", Fusion Engineering and Design, vol. 74, pp. 565-569, 2005.
- [10] K. Riße, M. Nagel, M. Pietsch, A. Braatz, A. Binni and H. Posselt, "Design and assembly technology for the thermal insulation of the W7-X cryostat", Magnetism, vol. 86, pp. 720–723, 2011.
- [11] A. Kuendig, C. P. Dhard, S. Raatz, H. Bau, "Progress Report of the Cryo-Plants for Wendelstein-7X", Proc. 22nd Int. Cryog. Eng. Conf., Seoul, Korea (2008).
- [12] R. Stadler, A. Vorköper, J. Boscary, A. Cardella, F. Hurd, C. Li et al., "The in-vessel Components of the Experiment Wendelstein 7-X", Fusion Eng. Des., vol. 84, pp. 305-308, 2009.
- [13] T. Rummel, K. Riße, J. Kiblinger, M. Köppen, F. Füllenbach, H. Neilson, T. Brown and S. Ramakrishnan, "The trim coils for the Wendelstein 7-X magnet system", IEEE Transactions on Applied Superconductivity, vol. 22, 4201704, 2012.
- [14] T. Rummel, K. Riße and H. Ehmler, "Manufacture and test of the non-planar coils for Wendelstein 7-X", Fusion Engineering and Design, vol. 74, pp. 117-120, 2005.
- [15] H. Viebke, T. Rummel, K. Riße, R. Schroeder and R. Winter; "Fabrication of the planar coils for Wendelstein 7-X", Fusion Engineering and Design, vol. 74, pp. 201-205, 2005.
- [16] V. Bykov, F. Schauer, K. Egorov, A. Tereshchenko, P. van Eeten, A. Dübner et al., "Structural analysis of W7-X: Overview", Fusion Engineering Design, vol. 84, pp. 215-218, 2009.
- [17] R. Jaenicke, E. Ascasibar, P. Grigull, I. Lakicevic, A. Weller, M. Zippe et al., "Detailed investigation of the vacuum magnetic surfaces on the W7-AS stellarator", Nuclear Fusion, vol. 33, pp. 687, 1993.
- [18] R. Vilbrandt, H.-S. Bosch, J.-H. Feist, "Do we need a quality management system in fusion research? Experience from Wendelstein 7-X", proceedings of the 25th Symposium on Fusion Engineering (SOFE), San Francisco, June 2013.



Hans-Stephan Bosch received the Dipl.-Phys. Degree from Ludwigs-Maximilians University, Munich in 1983, the Dr. rer. nat. degree from the Technical University, Munich in 1986 and the Habilitation from Humboldt University of Berlin in 2000; Since 2008 he has been a Lecturer with the

Ernst Moritz Arndt University in Greifswald. He is currently the Associate Director of the Wendelstein 7-X project and Division head W7-X Operations with the Max-Planck-Institute for Plasma Physics, Greifswald. His research interests are plasma edge and divertor physics.

Rudolf Brakel received the Diploma in physics from Ruhr University, Bochum, Germany in 1983 and the Dr.rer.nat. degree from Julius-Maximilians-University, Würzburg, Germany, in 1987. He has been with the Max-Planck-Institute for Plasma Physics, Garching, Germany, where he has been doing research on stellarators since 1987, and has been a member of the Wendelstein 7-X project at the Max-Planck-Institute for Plasma Physics, Greifswald, since 2002. He is currently member of the Division W7-X Operations. His major research interests are confinement in stellarators and stellarator operation.
(photograph not available)



Maurizio Gasparotto received the Doctor degree with honors in Physics from the University of Rome. He was visiting professor at the University of Bologna from 1985 to 2002. He is currently the Chief Engineer of the Wendelstein 7-X project. He has been Deputy Director of the ENEA Fusion Department for the fusion technologies until

2000. Successively has been: head of the Field "Tritium Breeding and Materials" in EFDA (2000-2003); responsible of the division System Engineering in the Wendelstein 7-X project (2003-2005); EFDA Associate Leader for Technology and European Participant Team Leader in the ITER Project (2005- 2008) and Chief Engineer in Fusion for Energy: the European Domestic Agency for the ITER construction (2008-2011).

Heinz Grote (CV and photograph not available)



Dirk A. Hartmann received a Ph.D. in physics from the University of California, San Diego, in 1994. He has been at the Max-Planck Institute for Plasma Physics since 1995, first working in radio frequency plasma heating on Wendelstein 7-AS and general plasma operation of the device. Since 2007 he is Division head of design and configuration management of the project Wendelstein 7-X.



René Herrmann received his Master of Business and Engineering Degree from the University for applied Sciences in Wildau in 2004. His professional experience he got by working of 15 years in project management in a division of the Daimler Benz Group.

Since 2008 he is a staff member of the project control department of the Wendelstein 7-X project with the Max Planck Institute for Plasma Physics. Greifswald.



Michael Nagel studied Chemical Engineering at Technical University of Karlsruhe (TH). There he received his Dipl.-Ing. degree in 1990 and his Dr.-Ing. degree in 1995. After a few years in industry he joined the Max-Planck-Institute for Plasma Physics, Greifswald in 1999. Since then he has been

working on cryogenics for the Wendelstein 7-X project. He is currently leader of the cryogenic department of W7-X. His working field covers thermo-dynamics, fluid dynamics and their applications in cryogenics.

Dirk Naujoks Dirk Naujoks has studied at the Moscow Power Engineering Institute (1983-1989) and acquired his PhD from Lomonosov Moscow State University (1991). From 1991 he has worked at the Max-Planck-Institute of Plasmaphysics (IPP) at its different sites Garching and Berlin and now in the Stellarator project W7-X in IPP in Greifswald. In 1999 he stayed a half year at the Argonne National Laboratory as a guest scientist. From 2001 to 2009 he gave lectures at the Humboldt University of Berlin on Computer Simulation in Plasma Physics and he received the Habilitation from Humboldt University of Berlin in 2008.
(photograph not available)

Matthias Otte (CV and photograph not available)

Konrad Riße (CV and photograph not available)

Thomas Rummel received the Dipl.-Ing. degree for Electrical Engineering in 1989 and the Dr.-Ing. degree in 1996 from Otto-von-Guericke University of Magdeburg, Germany.
He is currently the head of the Wendelstein 7-X Magnets and Cryostat division with the Max-Planck-Institute for Plasma Physics, Greifswald.
(photograph not available)

Andreas Werner (CV and photograph not available)